

PZA

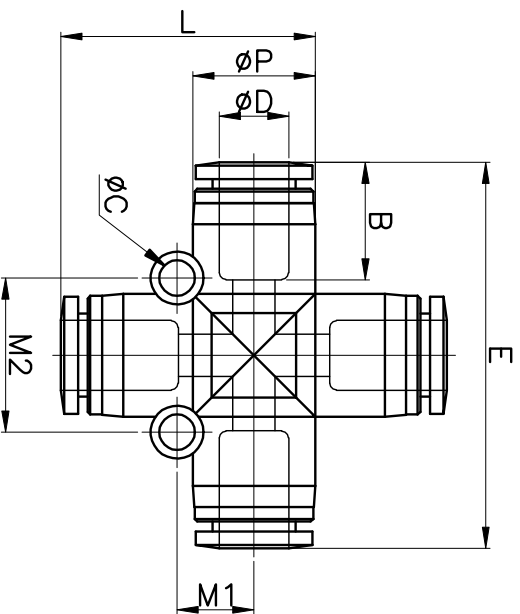

MODEL	ØD	ØP	L	E	ØC	B	M1	M2	ORIFICE	WEIGHT (g)	BOX(EA)
PZA04	4	10.5	23.2	35.9	3.3	14.9	6.4	12.7	2.6	9.0	50
PZA06	6	12.5	27.0	41.5	3.3	16.4	7.4	14.9	4.5	12.0	50
PZA08	8	14.5	30.0	45.6	4.2	18.7	9.1	18.2	6.0	18.0	25
PZA10	10	17.5	32.9	48.4	4.3	20.1	10.1	20.3	7.4	24.0	25
PZA12	12	20.5	37.9	55.3	4.3	22.8	11.8	23.7	9.0	40.0	20